

# Rolls

**S2-1070GEL**  
2V 1070 AH @C20

**TUBULAR POSITIVE - OPzV - VALVE REGULATED GEL BATTERY**



**CONSTANT CURRENT DISCHARGE**

CUT OFF VOLTAGE V/CELL	30MIN	1HR	2HR	3HR	4HR	6HR	8HR	10HR	20HR
1.75V	780.0	557.0	347.0	252.2	197.0	153.0	118.3	102.0	53.55



**Rolls**  
BATTERY ENGINEERING  
BY SURRETTE BATTERY COMPANY

**SPECIFICATIONS**

Nominal Voltage		2 Volt
Rated Capacity (20 hour rate)		1070 AH
Dimensions	Total Height (including terminals)	681mm / 26.81"
	Length	233mm / 9.17"
	Width	210mm / 8.27"
	Weight	176.37 lbs / 80 Kg



**CHARACTERISTICS**

Capacity 77°F (25°C)	100 Hour Rate	1250 AH
	20 Hour Rate	1070 AH
	10 Hour Rate	1000 AH
Internal Resistance	Full charged Battery 77°F (25°C)	0.27mΩ
Capacity Affected by Temperature (20hr rate)	104°F (40°C)	105%
	77°F (25°C)	100%
	32°F (0°C)	89%
	5°F (-15°C)	79%
Self-Discharge	Less than 2% per month at 77°F (25°C)	
Max Discharge 77°F (25°C)	3800A (5s)	
Terminal	Standard	Thread insert & Bolt (F10-M8)
Float Charging Voltage Range	2.25 to 2.3 VDC/unit Average at 25°C	
Max Charge Current	200 Amps	

**CYCLE LIFE**

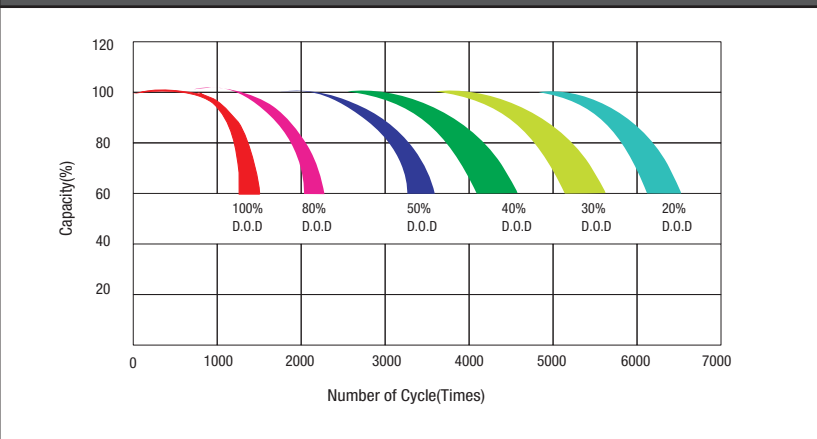

**SIZE & DETAILED ILLUSTRATION**

Dimension: 233mm (9.17")L x 210mm (8.27")W x 681mm (26.81")H

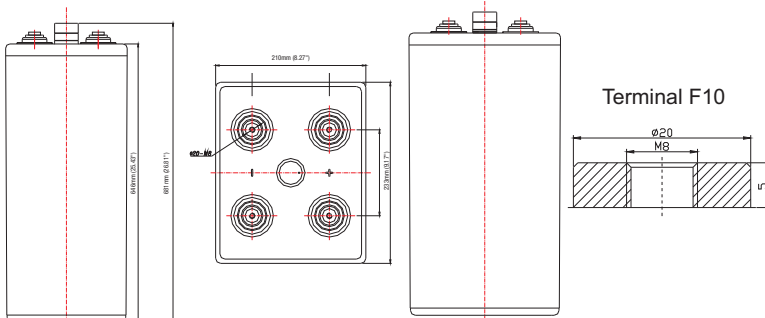

**TEMP EFFECTS ON LIFE AT FLOAT CHARGE**

